

LOC		DIST		REVISIONS			
CM	00	REV	DATE	BY	APP'D		
J1		REVISED PER ECO-07-001393	8JUL05	KW	DB		

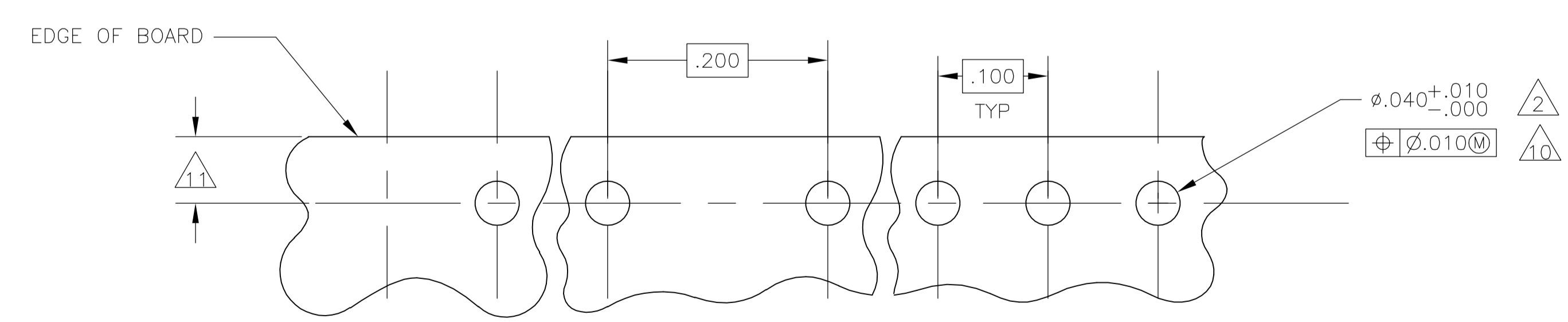
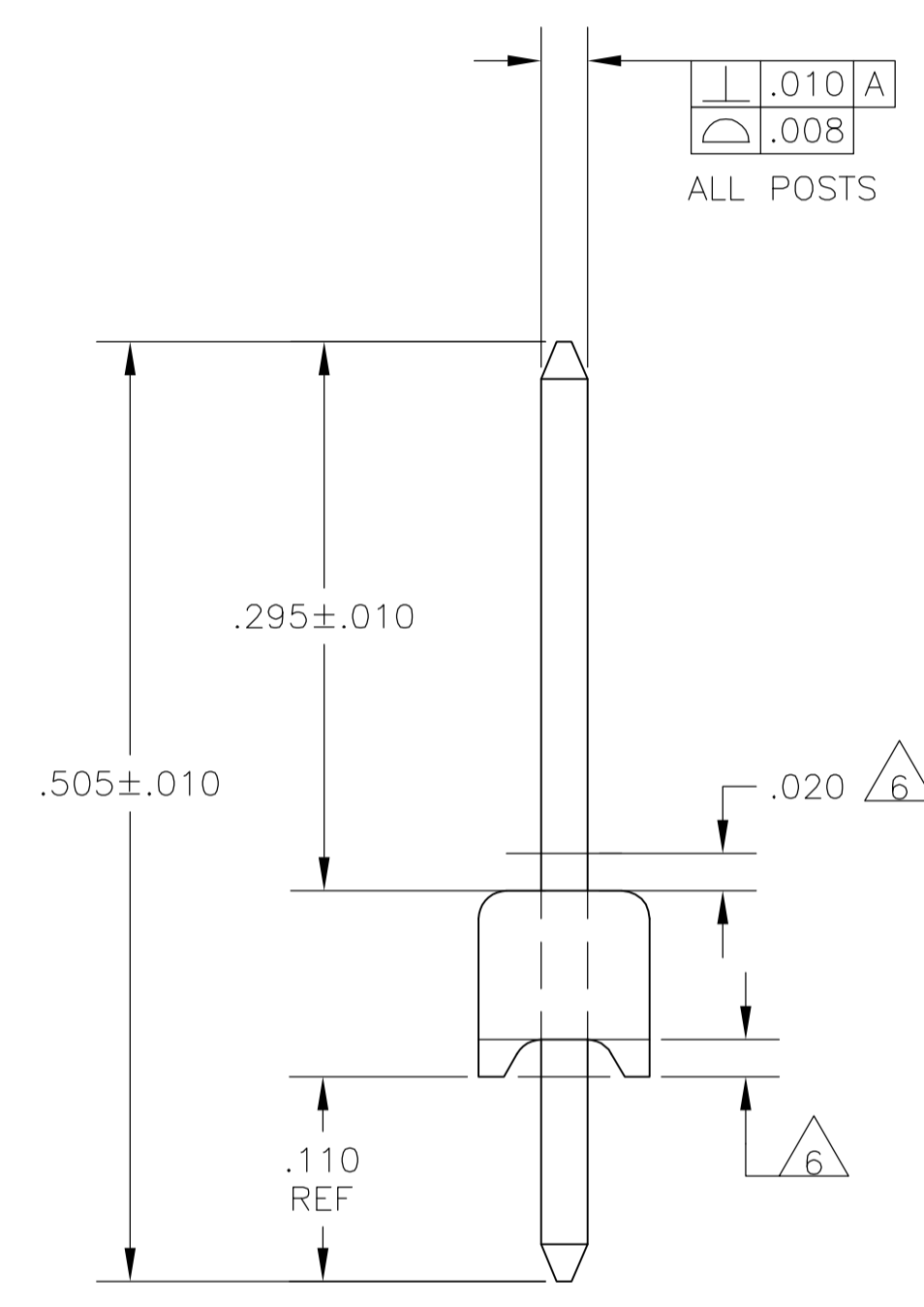
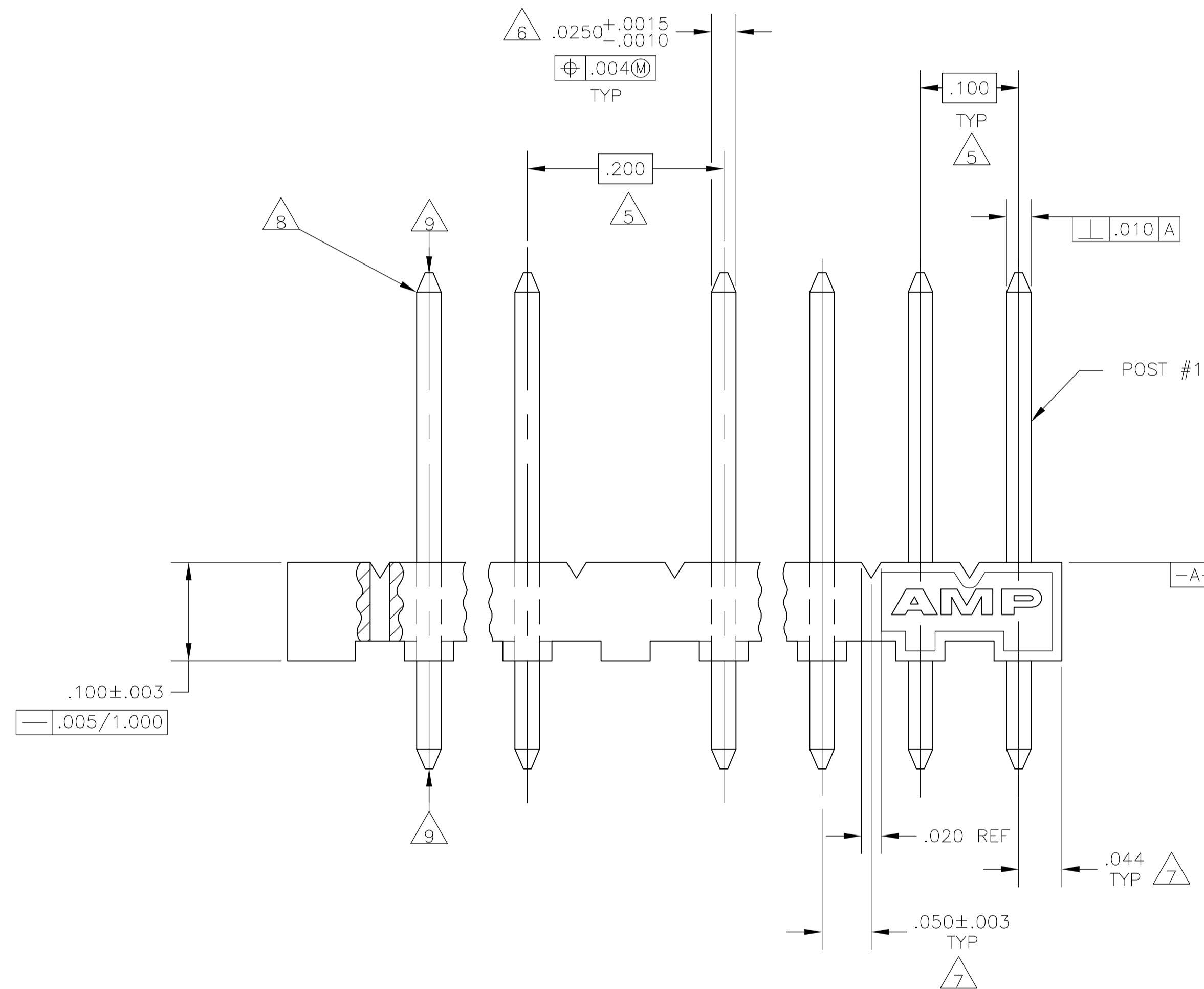
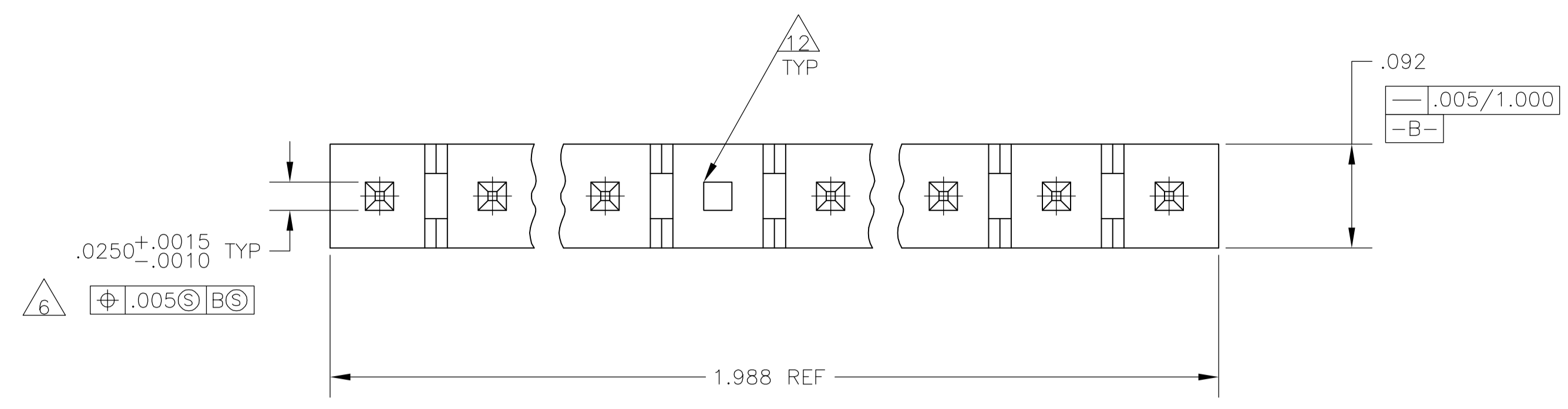

RECOMMENDED MOUNTING HOLE PATTERN FOR .063 THICK P. C. BOARD

- 1 MATERIAL:
BASE: THERMOPLASTIC POLYESTER, UL 94V-0 (NATURAL).
POST: COPPER ALLOY (TIN OR TIN-LEAD PLATED, .000150" MIN THICK-SEE PART NUMBER TABLE FOR DETAILS).
- 2 ONE HOLE MAY BE UNDERSIZED (.032-.035 DIA) FOR ASSEMBLY RETENTION DURING WAVE SOLDERING.
- 3. PARTS MUST COMPLY WITH AMP SOLDERABILITY SPEC 109-11-2.
- 4 PLASTIC AROUND POST PERMISSIBLE IN THIS AREA ONLY.
- 5 DIMENSION APPLIES WHEN HEADER IS HELD FLAT.
- 6 MEASURED AT -A-
- 7 COORDINATE DIMENSION APPLIES FROM CENTER OF ACTUAL FEATURE.
- 8 RADIUS AT TIP PERMITTED, BOTH ENDS.
- 9 POST MUST WITHSTAND 3.0 LB MIN AXIAL FORCE IN BOTH DIRECTIONS WITHOUT DISLODGING.
- 10 SOLDER SIDE OF BOARD IS SHOWN.
- 11 DIMENSION SHOULD BE .060 MIN WHEN MATING WITH A MTA-100 CONNECTOR ASSEMBLY OR A CST-100 CONNECTOR.
- 12 HOLE IN OMITTED POST LOCATION MAY NOT BE PRESENT.
- 13. AMP LOGO MAY OR MAY NOT APPEAR ON MOLDING HOUSING.

IN	MM	IN	MM
.035	0.89	1.988	50.50
.032	0.81	1.000	25.40
.0250	0.635	.505	12.83
.025	0.64	.295	7.49
.020	0.51	.200	5.08
.010	0.25	.110	2.79
.008	0.20	.100	2.54
.005	0.13	.092	2.34
.004	0.10	.063	1.60
.003	0.08	.060	1.52
.0015	0.038	.050	1.27
.0010	0.025	.044	1.12
.000150	0.0038	.040	1.02
IN	MM	IN	MM

SUPERSEDED BY 3-644352-3

TIN	10 & 14	3-644352-3
TIN LEAD	10 & 14	644352-3
FINISH	POST NO. OMITTED	PART NUMBER

THIS DRAWING IS A CONTROLLED DOCUMENT.

DIMENSIONS:	TOLERANCES UNLESS OTHERWISE SPECIFIED:	APPROVED:	DATE:	NAME:	COMPANY:
INCHES:	0 PLC ± -	D. BOSSI	08JULY2005	D. BOSSI	Tyco Electronics Corporation
	1 PLC ± -				Harrisburg, Pa 17105-3608
	2 PLC ± -				
	3 PLC ± .005				
	4 PLC ± -				
	ANGLES ± -				
MATERIAL:	FINISH:	SIZE:	WEIGHT:	SCALE:	RESTRICTED TO:
1	1	A1	00779	10:1	644352
CUSTOMER DRAWING		SHEET	1 OF 1	REV	J1

